

Apache Lifts



Model#: TS12

Heavy-Duty
12,000 lb. 2-Post Lift

**12,000 LB
2-POST LIFT**

Apache Lifts TS12 two post lift boasts a 12,000 lb. lifting capacity, heavy-duty symmetric lifting configuration, and adjustable height that accommodates higher profile vehicles. It's competitive price and professional quality makes it a perfect choice for the budget conscious service facility.

Additional TS12 features include heavy-duty two stage telescoping arms with automatic arm restraints, protective rubber door guards, single point mechanical lock release and padded overhead shutoff system. Available in red and blue only.

FEATURES AND BENEFITS:

- Heavy-Duty two-stage telescoping arms provide excellent reach and retraction to accommodate vehicle lifting points
- 13' 10" or 14' 7" adjustable column height accommodates higher profile vehicles and provides maximum headroom to work underneath vehicles
- Heavy-Duty telescoping Screw Pads adjust to multiple heights minimizing the need for adapters
- Padded overhead shut off system prevents vehicle damage from being raised too high
- Single-point mechanical lock release system allows technician to disengage both columns simultaneously
- Rubber door guards protect vehicle from door damage
- Premium powder coat finish provides long-lasting durability
- Plated Arm Restraints and Arm Pins inhibit rust and provide long-lasting durability

Optional Accessory:

Part #AP-10318 Set of (4) Frame Engaging Truck Adapters



FOR MORE INFORMATION CONTACT YOUR AUTHORIZED APACHE LIFTS DISTRIBUTOR

Model Number	TS12
Lifting Capacity*	12,000 lb. (5443kg)
A Rise Height	78 1/8" (1984mm)
B Adjustable Column Height	13' 10" or 14' 7" (4216mm or 4445mm)
C Overall Width	11' 7 3/4" (3550mm)
D Drive-thru Clearance	103" (2616mm)
E Floor to Overhead Switch	13' 3 1/2" or 14' 1/2" (4051mm or 4280mm)
F Arm Reach (Min.)	35 3/4" (910mm)
G Arm Reach (Max.)	54 1/2" (1386mm)
H Adj. Screw Pad Height	5 1/4" - 7 1/4" (133mm - 184mm)
Adj. Adapter Height (with 3" Extensions and Screw Pad)	8 1/4" - 10 1/4" (210mm - 260mm)
Adj. Adapter Height (with 6" Extensions and Screw Pad)	11 1/4" - 13 1/4" (286mm - 337mm)
I Inside of Columns	115" (2921mm)
Motor	2HP, Single Phase, 60Hz
Voltage	208 - 230v
Speed of Rise	66 seconds
Max. Load Per Arm	3,000 lb. (1361kg)
Ceiling Height Required	13' 11" or 14' 8" (4242mm or 4470mm)

*Lift capacity ratings are based on loads equally distributed on all four arms.

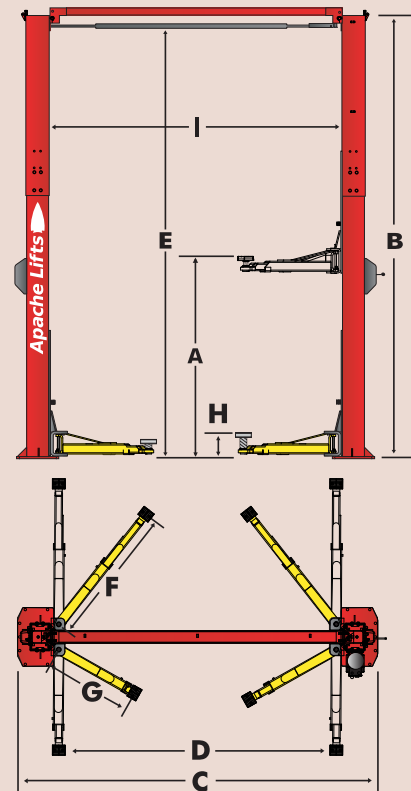

The Automotive Lift Institute (ALI) certifies that the TS12 described herein comply with the applicable provisions of the American National Standards ANSI/ALI ALCTV 2006 and are Third Party Validated by the ETL Testing Laboratory.

Apache Lifts Innovations
a division of Hergott
Automotive Equipment Inc.
37 McAllister Dr.
Bloomington, ON, N0B 1K0

800-461-1692
p: 519-658-3738
f: 519-569-7249
sales@apachelifts.com

Apache Lifts Innovations reserves the right to make changes to specifications without notice and without making changes retroactive. Unloading, installation and oil not included.